

VTB 25-2

VTB 25-3

**Montage- und
Gebrauchsanweisung**

**Installation and
Operating Instruction**

**Instruction d'installation
et d'utilisation**



**Verteilerbalken
DN 25, 125 mm
Achsabstand**

**Small manifold
DN 25, 125 mm
nozzle spacing**

**Barre de
distribution
DN 25, entraxe
125 mm**

Inhaltsverzeichnis

1	Maßzeichnung	DE-1
1.1	Verteilerbalken VTB 25-2.....	DE-1
1.2	Verteilerbalken VTB 25-3.....	DE-2
2	Produktbeschreibung und Lieferumfang.....	DE-3
2.1	Lieferumfang.....	DE-3
2.2	Technische Daten.....	DE-4
2.3	Druckverlust.....	DE-4
3	Darstellung des Anschlusswechsels	DE-5

1 Maßzeichnung

1.1 Verteilerbalken VTB 25-2

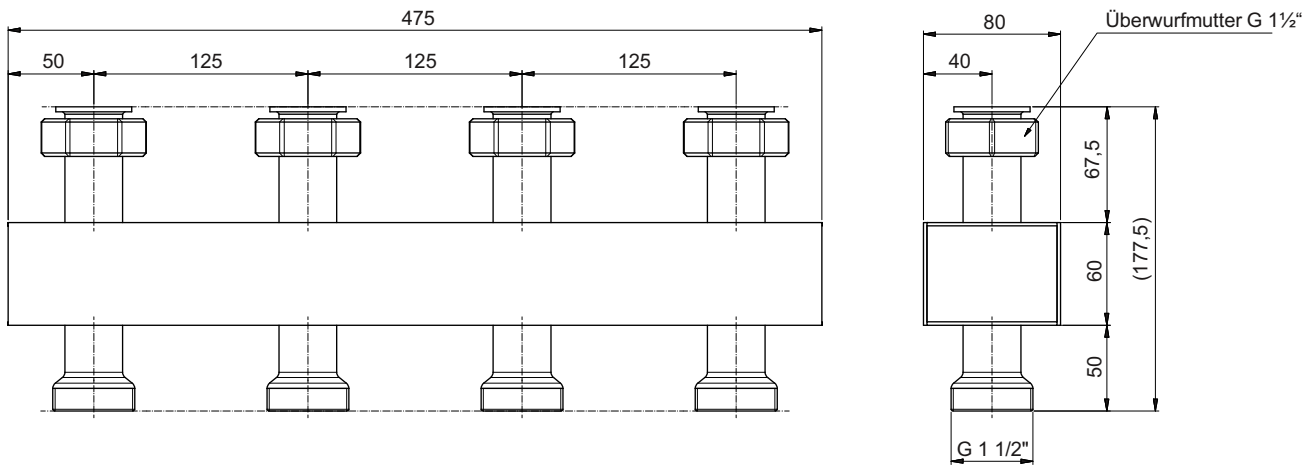

Inkl. Dämmung

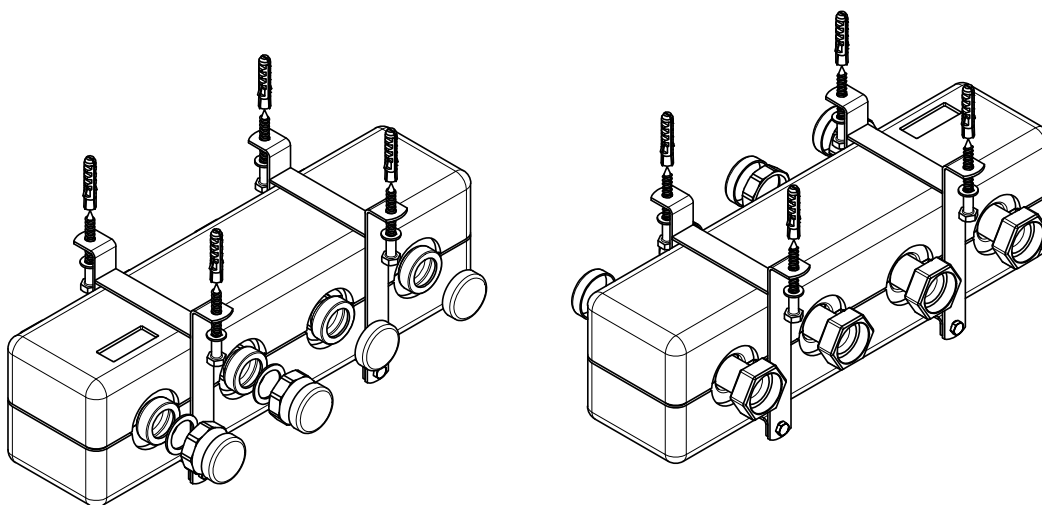
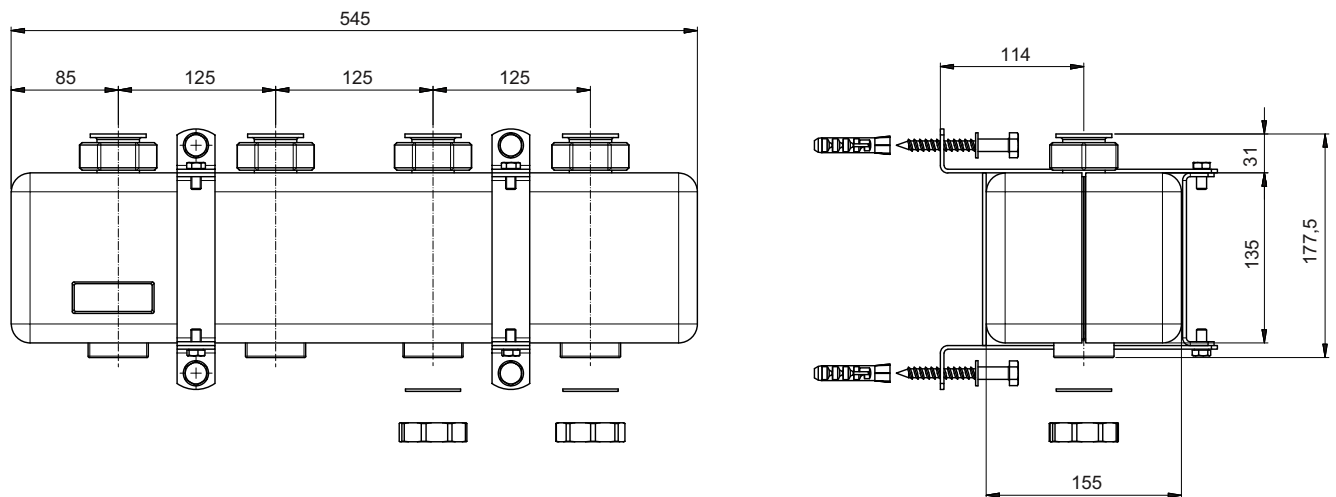

1.2 Verteilerbalken VTB 25-3

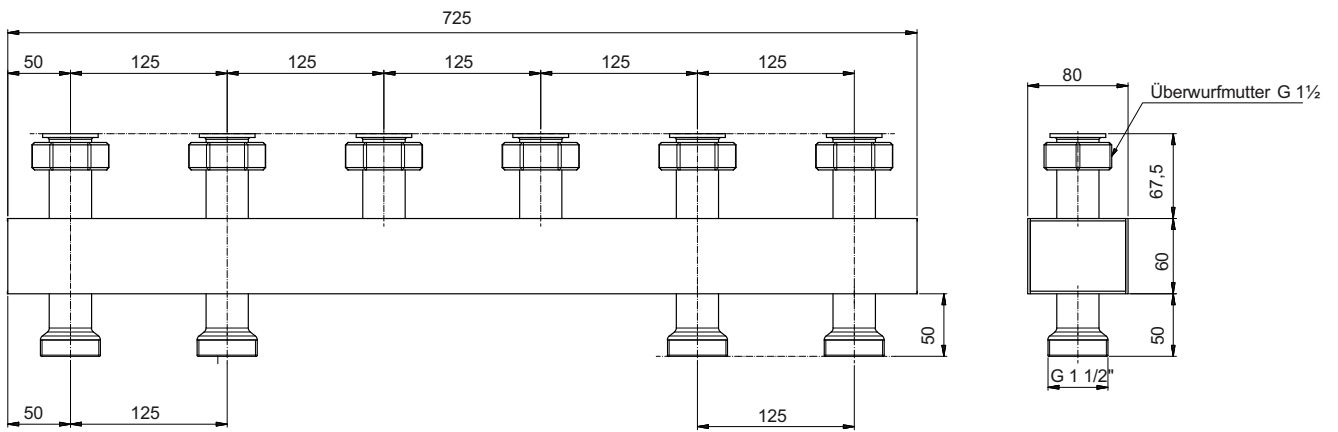

Inkl. Dämmung

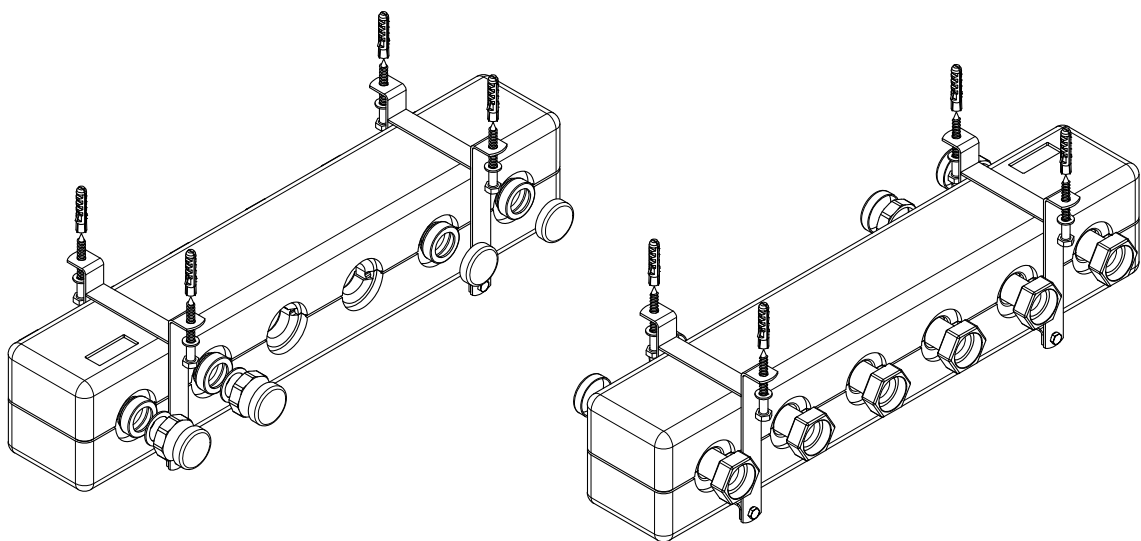
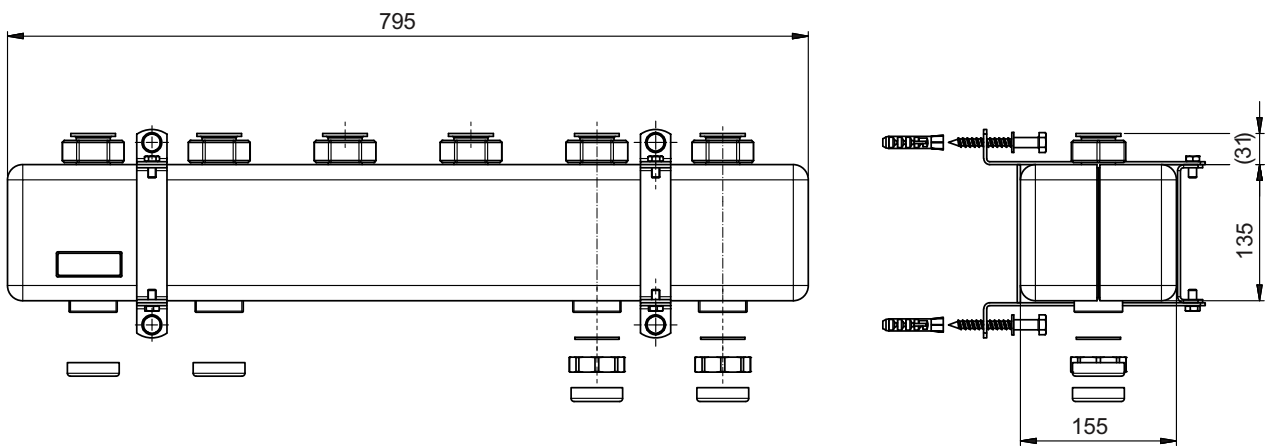

2 Produktbeschreibung und Lieferumfang

2.1 Lieferumfang

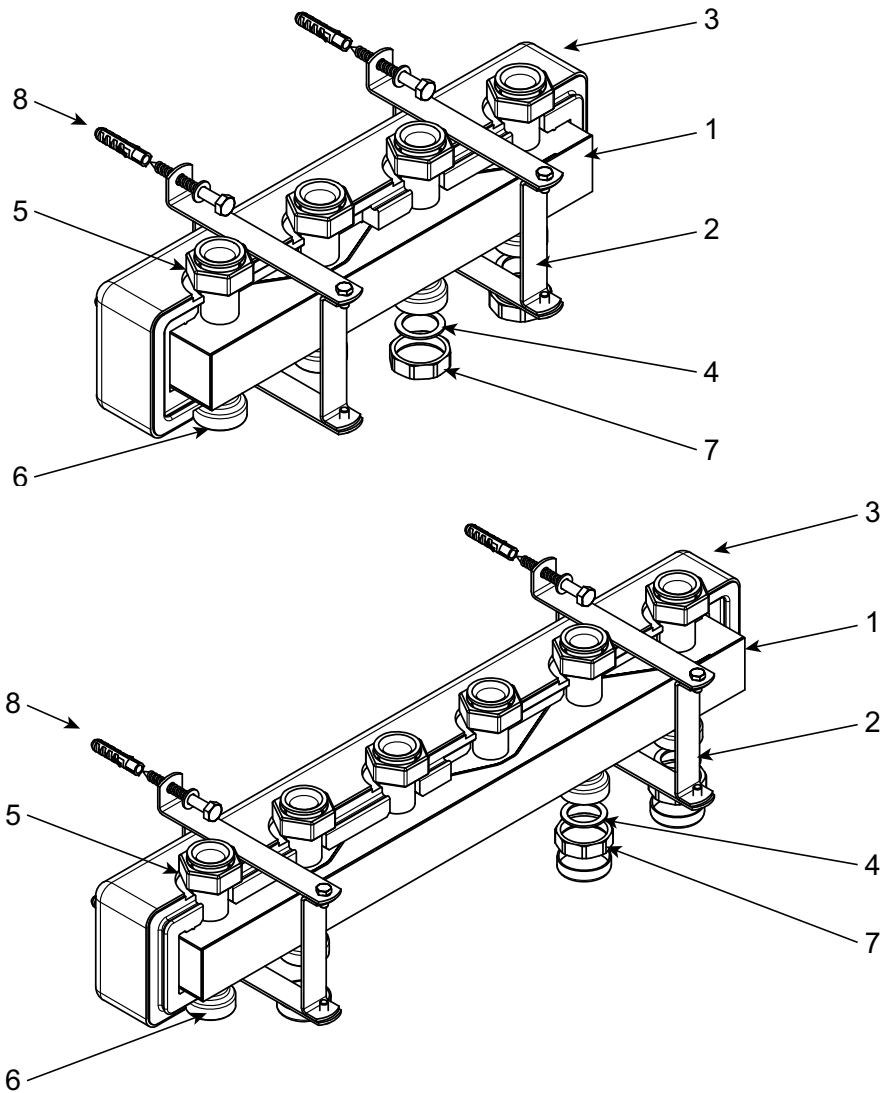

Position	Bezeichnung
1	Verteilerbalken 125 mm Stützenabstand
2	Fertigdämmung nach EnEV, 35 mm EPP-Schaum
3	Wandkonsole
4	Dichtungsringe
5	1 ½" Überwurfmutter für Heizkreisanschluss
6	G 1 ½" Gewindestutzen für Wärmepumpenkreis
7	Verschlusskappe 1 ½"
8	Befestigungs- und Montagematerial

2.2 Technische Daten

	VTB 25-2	VTB 25-3
Max. Volumenstrom	3,0 m ³ /h	3,0 m ³ /h
Anschluss Heizkreise	G 1 ½" Überwurfmutter	G 1 ½" Überwurfmutter
Anschluss Wärmepumpenkreis	G 1 ½" Außengewinde	G 1 ½" Außengewinde
Stützenabstand	125 mm	125 mm
Max. Betriebsdruck	4 bar	4 bar
Max. Betriebstemperatur	110 °C	110 °C
Wasserinhalt Verteiler	1,9 l	3,0 l

	Anzahl Heizkreis	Länge ohne Dämmung	Länge mit Dämmung	Artikel-Nummer
VTB 25-2	2	475 mm	545 mm	376360
VTB 25-3	3	725 mm	795 mm	376370

2.3 Druckverlust

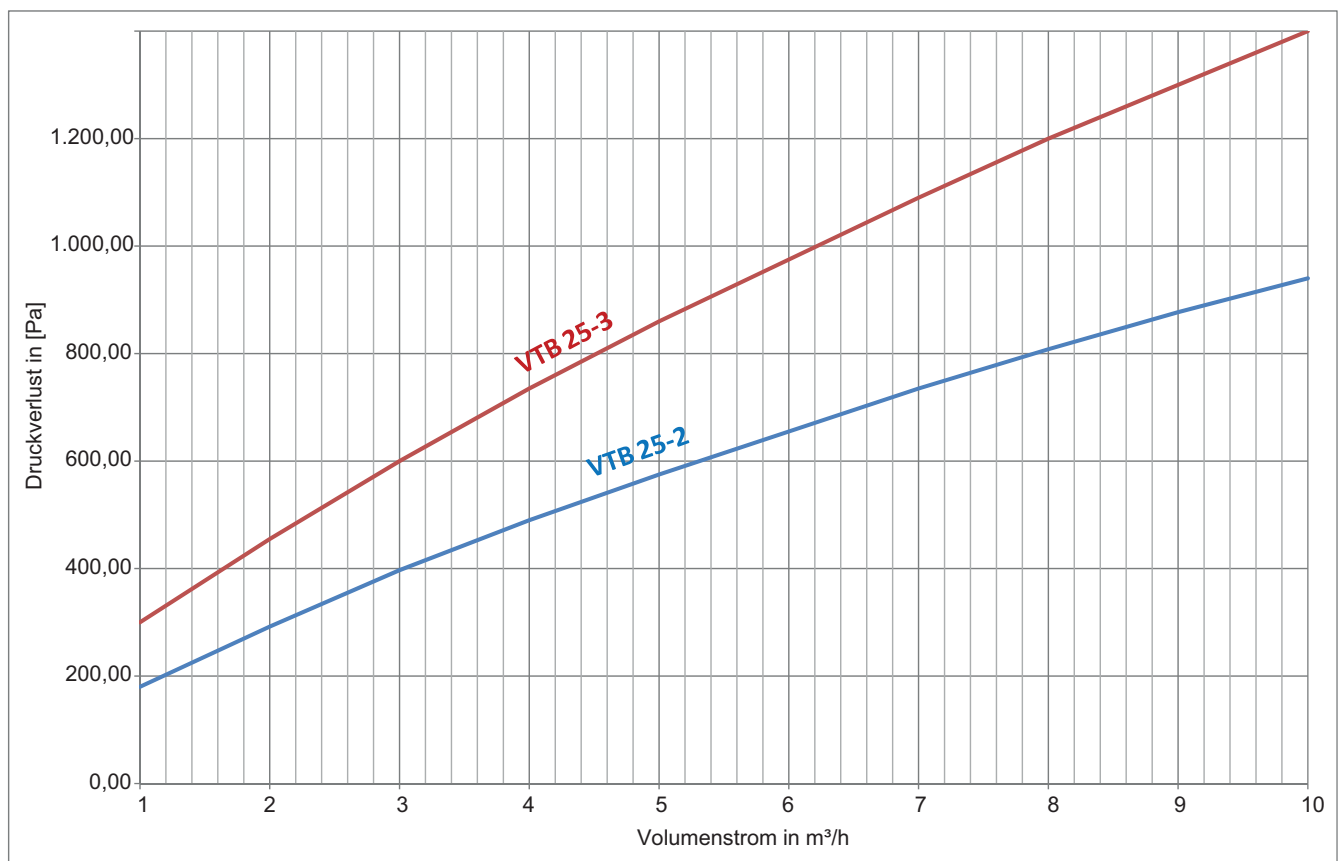

3 Darstellung des Anschlusswechsels

für 2 Heizkreise

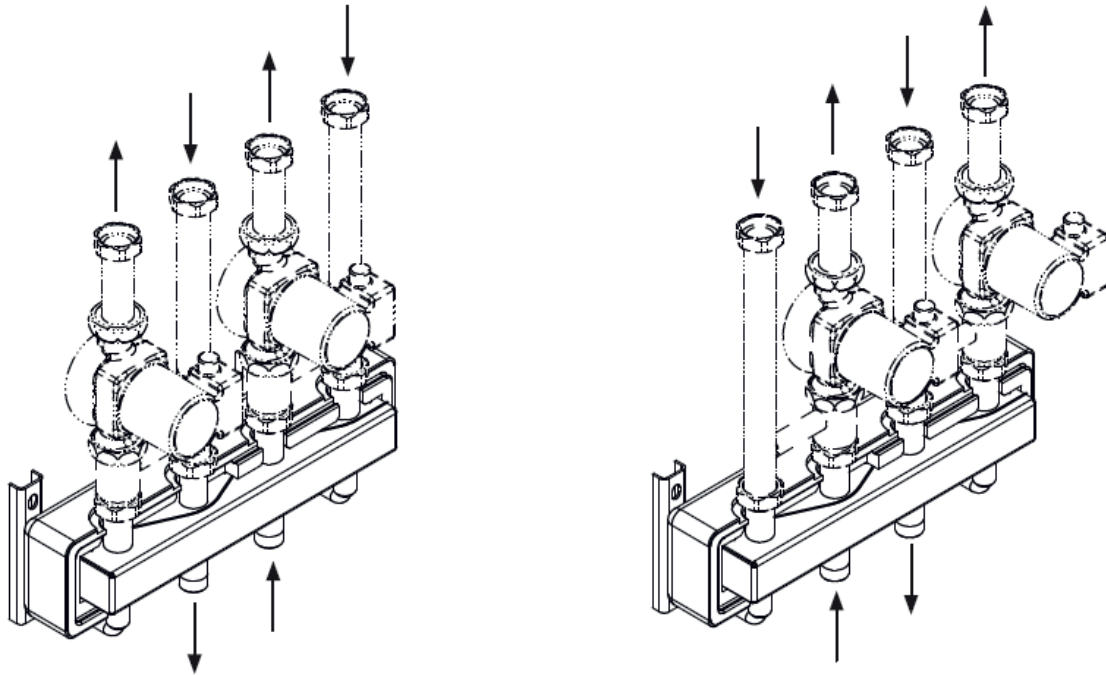

für 3 Heizkreise

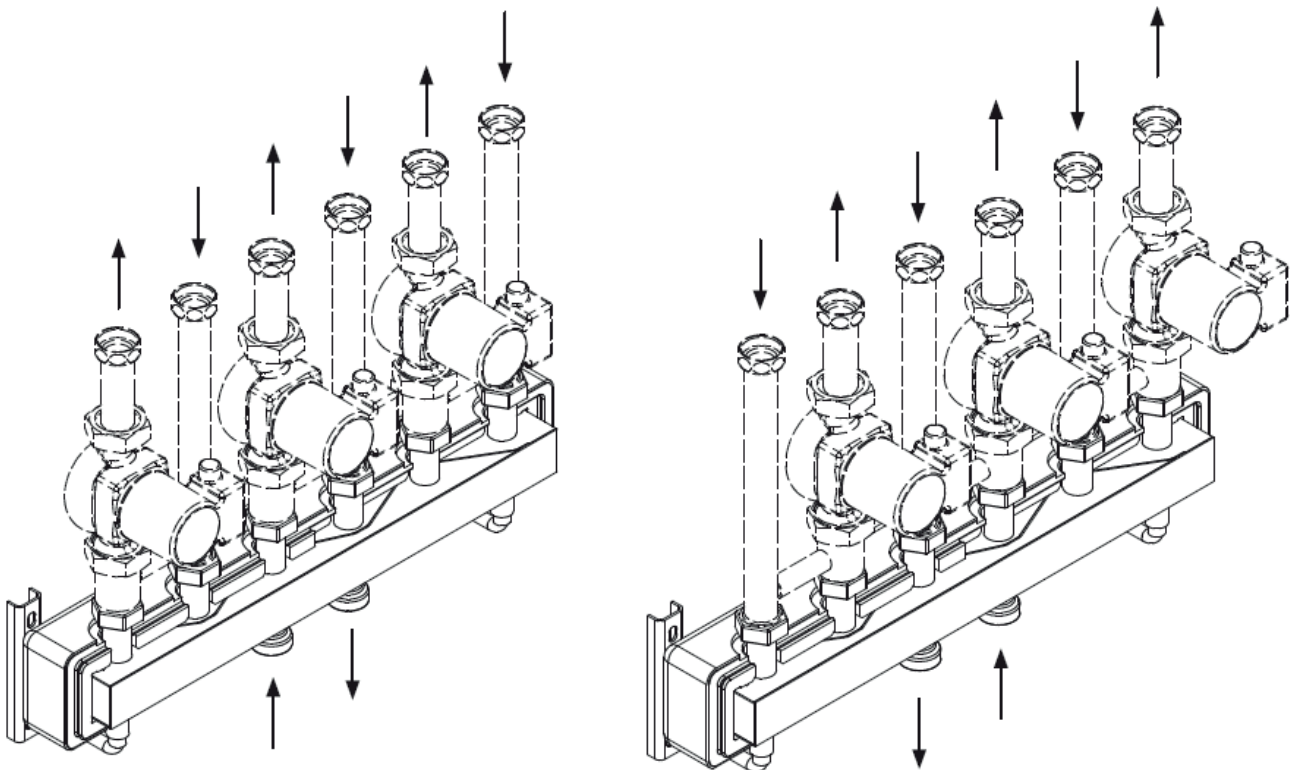
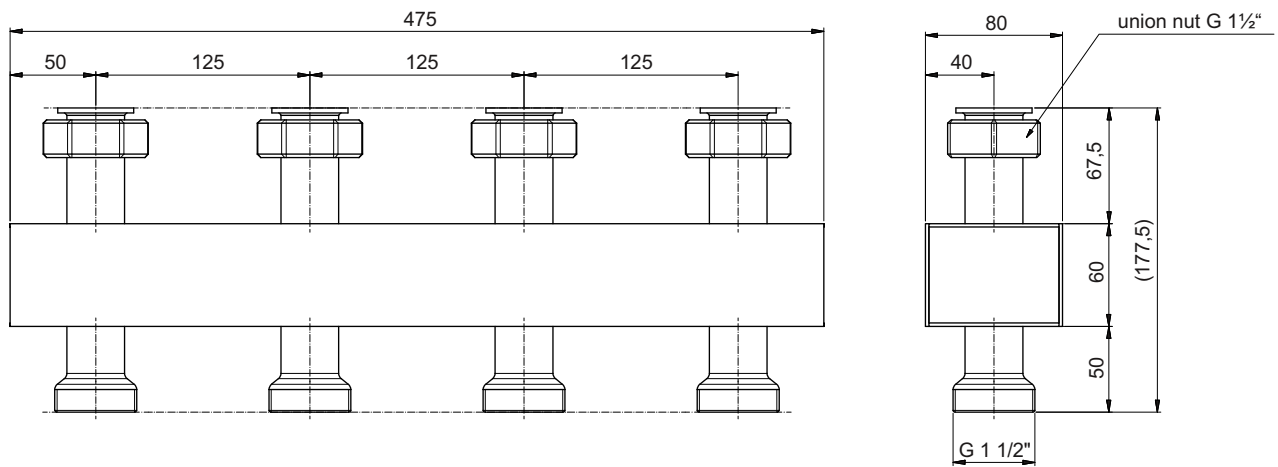

Table of Contents

1	Dimension drawing	EN-2
1.1	Manifold VTB 25-2	EN-2
1.2	Manifold VTB 25-3	EN-3
2	Productdescription and scope of delivery	EN-4
2.1	Scope of supply	EN-4
2.2	Technical data	EN-5
2.3	Pressure drop	EN-5
3	Illustration of switching the connections	EN-6

1 Dimension drawing

1.1 Manifold VTB 25-2



with insulation

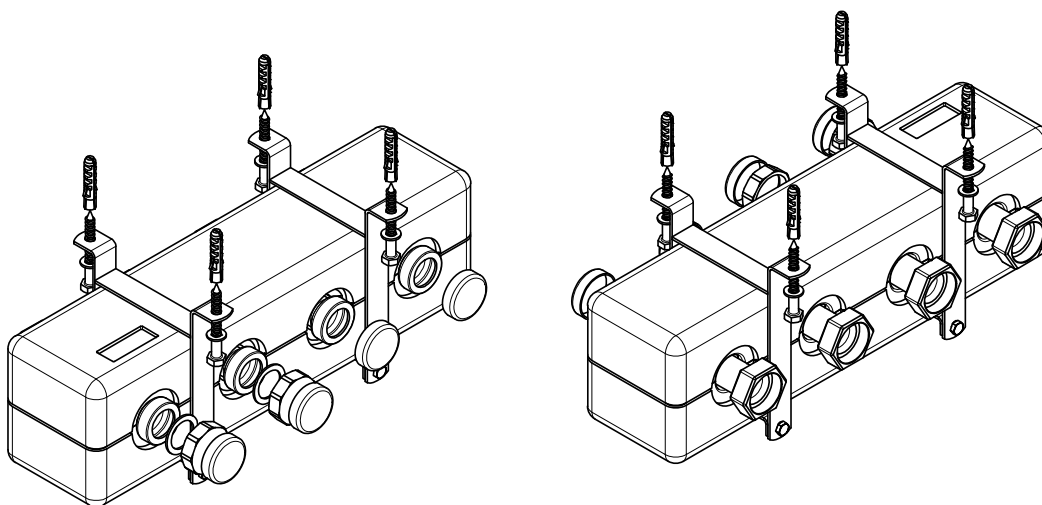
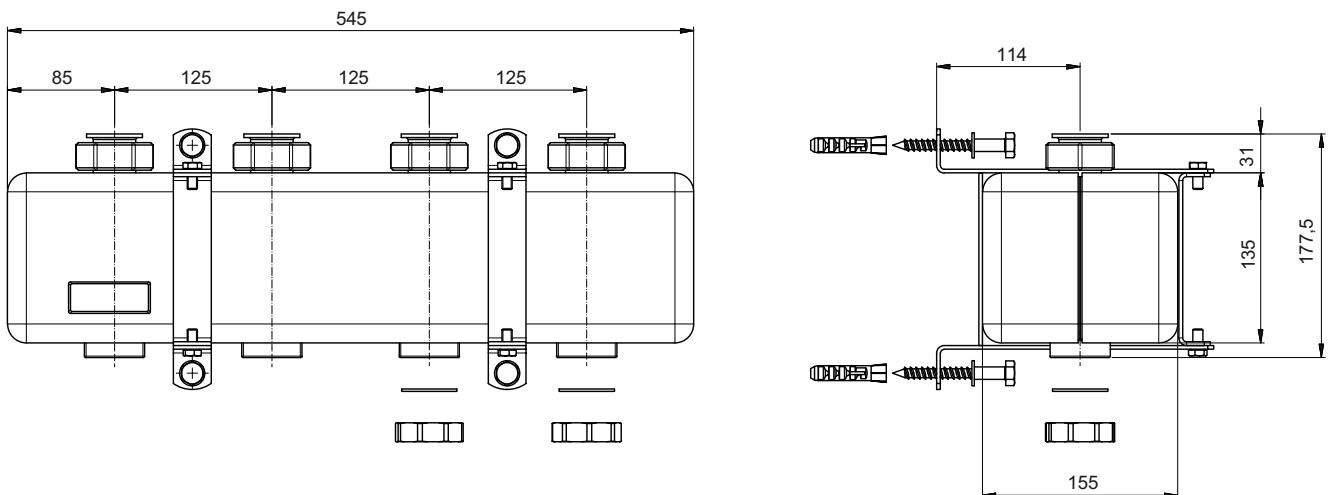

1.2 Manifold VTB 25-3

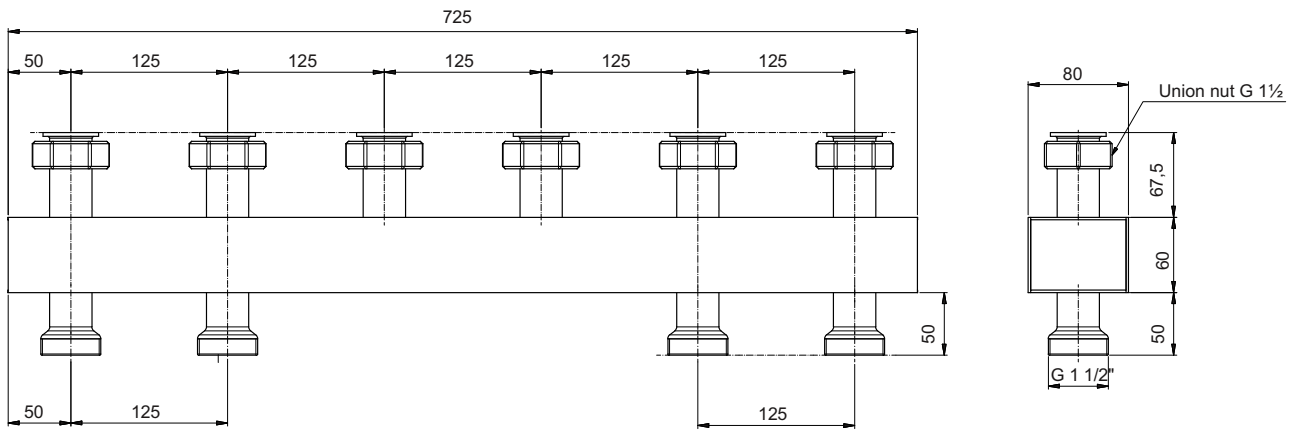

with insulation

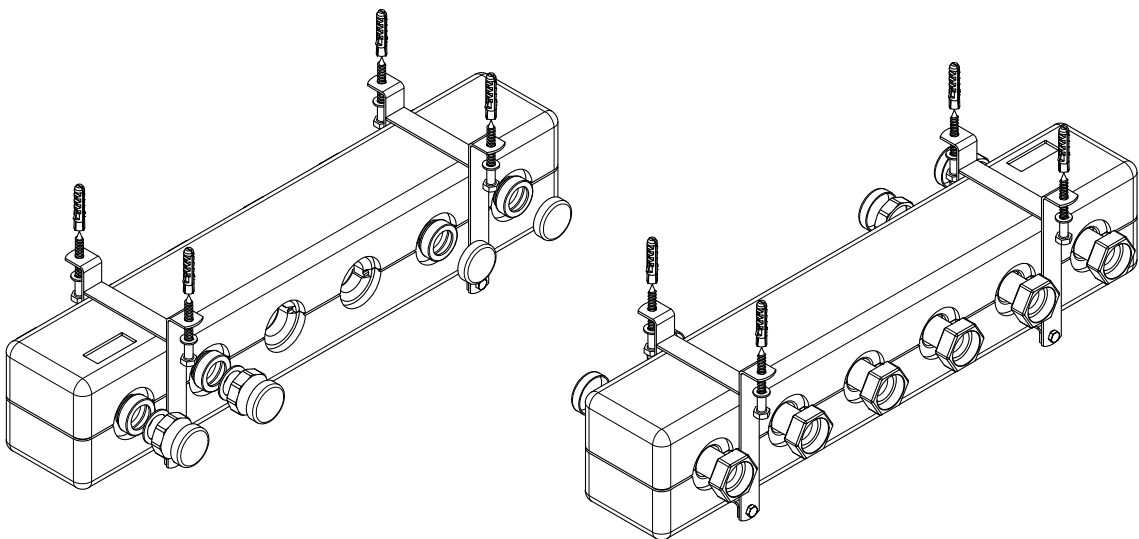
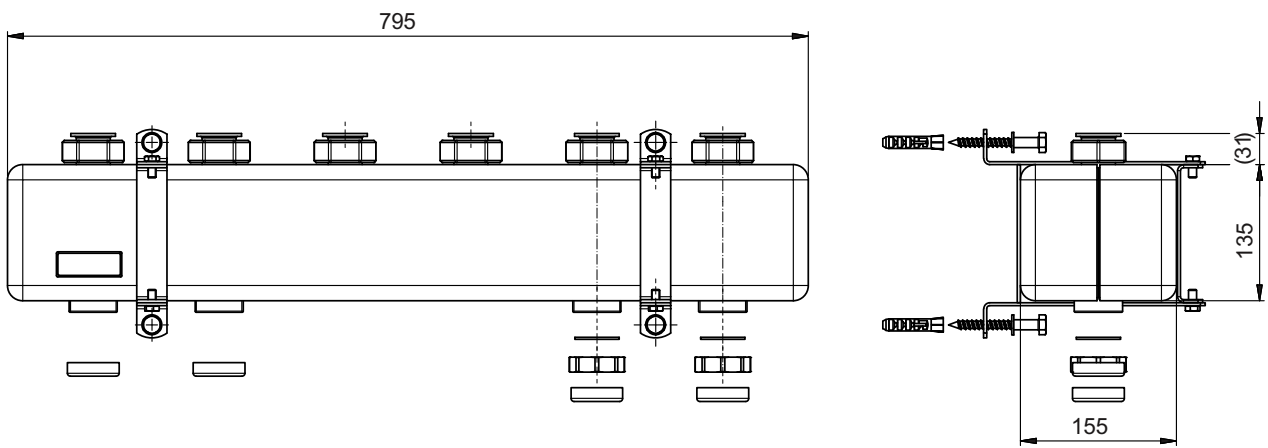

2 Productdescription and scope of delivery

2.1 Scope of supply

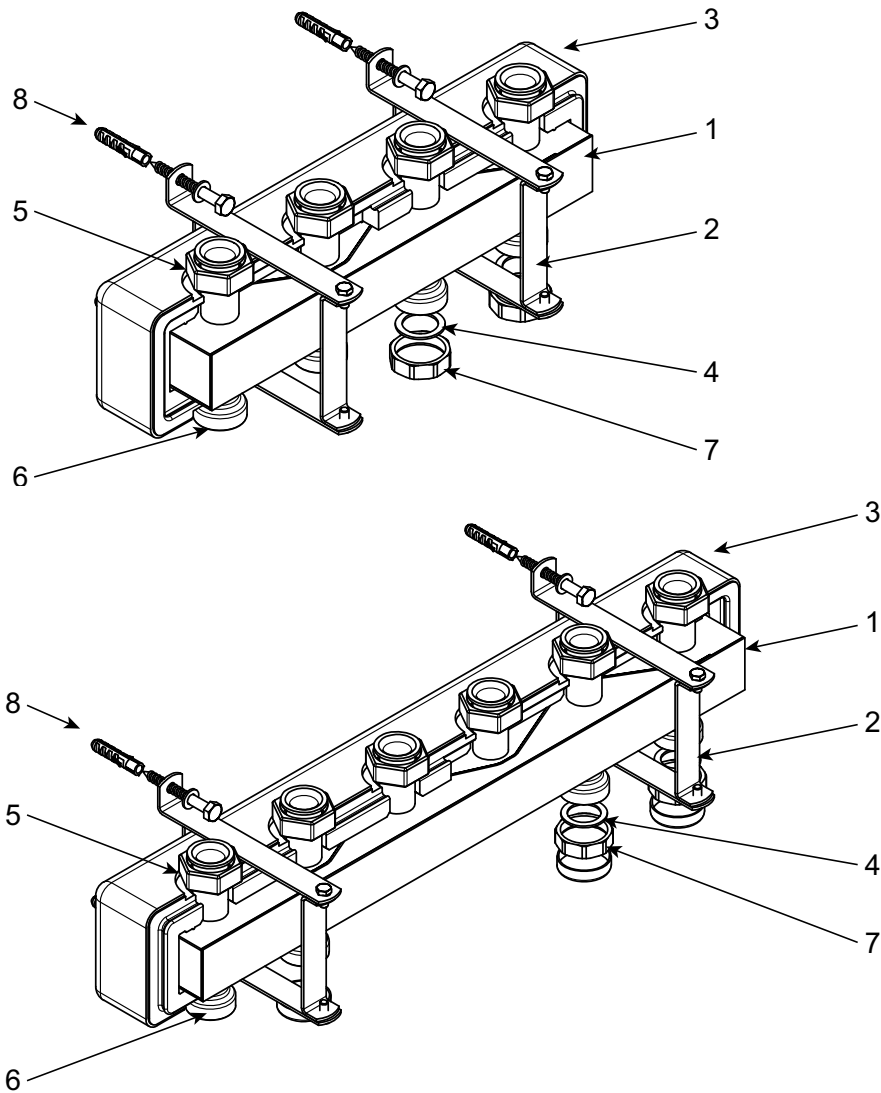

Position	Description
1	Mainfold 125 mm nozzle spacing
2	Insulation according to EnEV; 35 mm EPP foam
3	Mounting for wall bracket
4	Sealing ring
5	1 ½" union nut for heating cricuits connection
6	G 1 ½" external thread for heat pump circuit
7	Sealing cap 1 ½"
8	Fixing and assembly kit

2.2 Technical data

	VTB 25-2	VTB 25-3
Max. flow rate	3,0 m ³ /h	3,0 m ³ /h
Connection to heating circuits	G 1 ½" union nut	G 1 ½" union nut
Connection to heat pump circuit	G 1 ½" external thread	G 1 ½" external thread
Nozzle spacing	125 mm	125 mm
Operating overpressure max.	4 bar	4 bar
Operating temperature max.	110 °C	110 °C
Water content manifold	1,9 l	3,0 l

	Number of heating circuits	Length without insulation	Length with insulation	Article-Number
VTB 25-2	2	475 mm	545 mm	376360
VTB 25-3	3	725 mm	795 mm	376370

2.3 Pressure drop

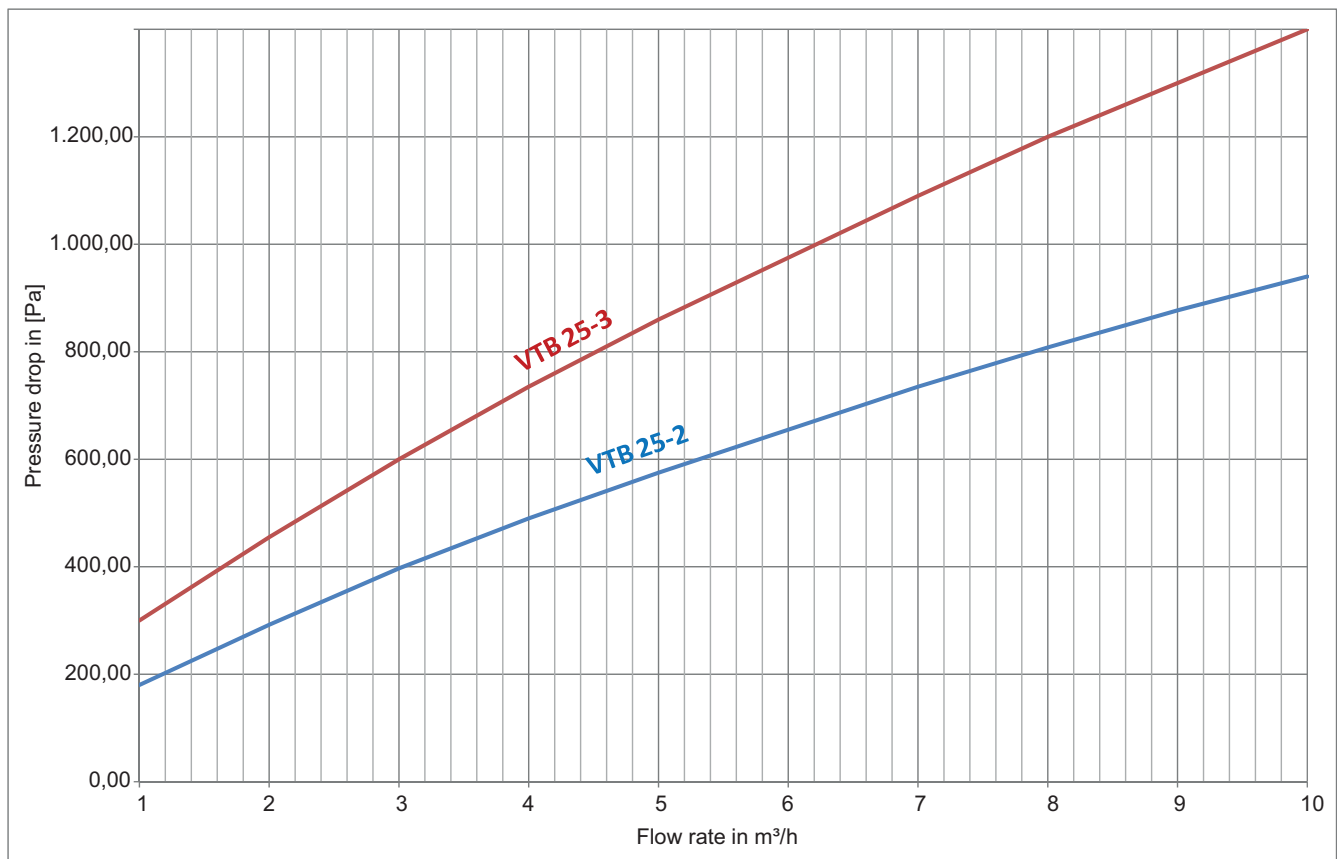

3 Illustration of switching the connections

for 2 heating circuits

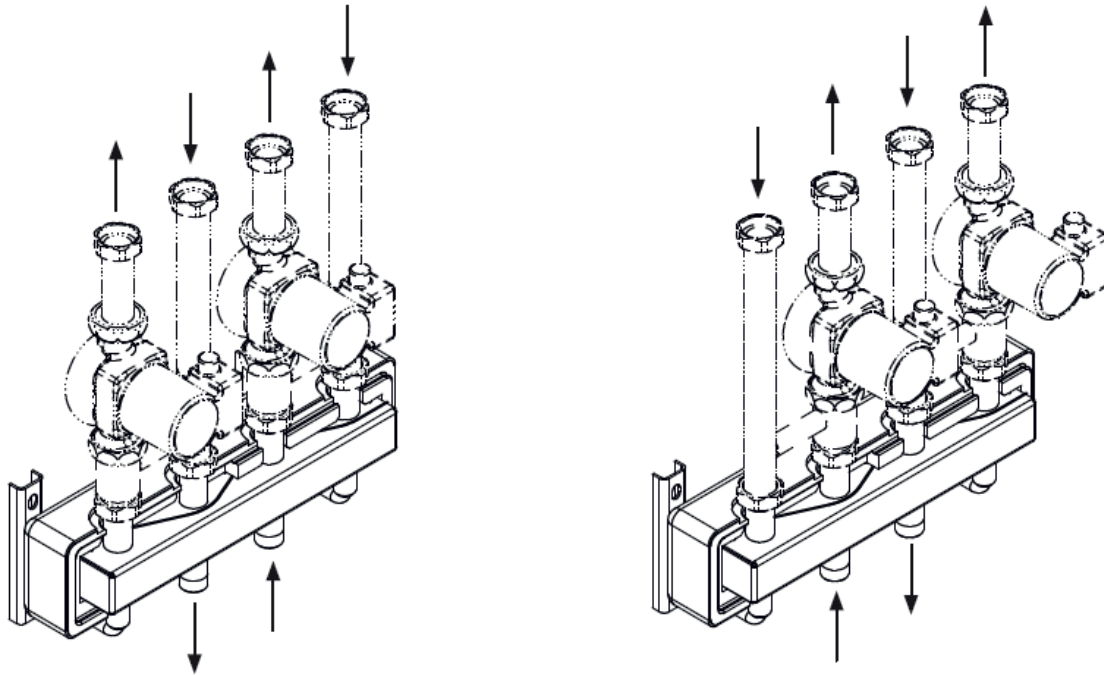

for 3 heating circuits

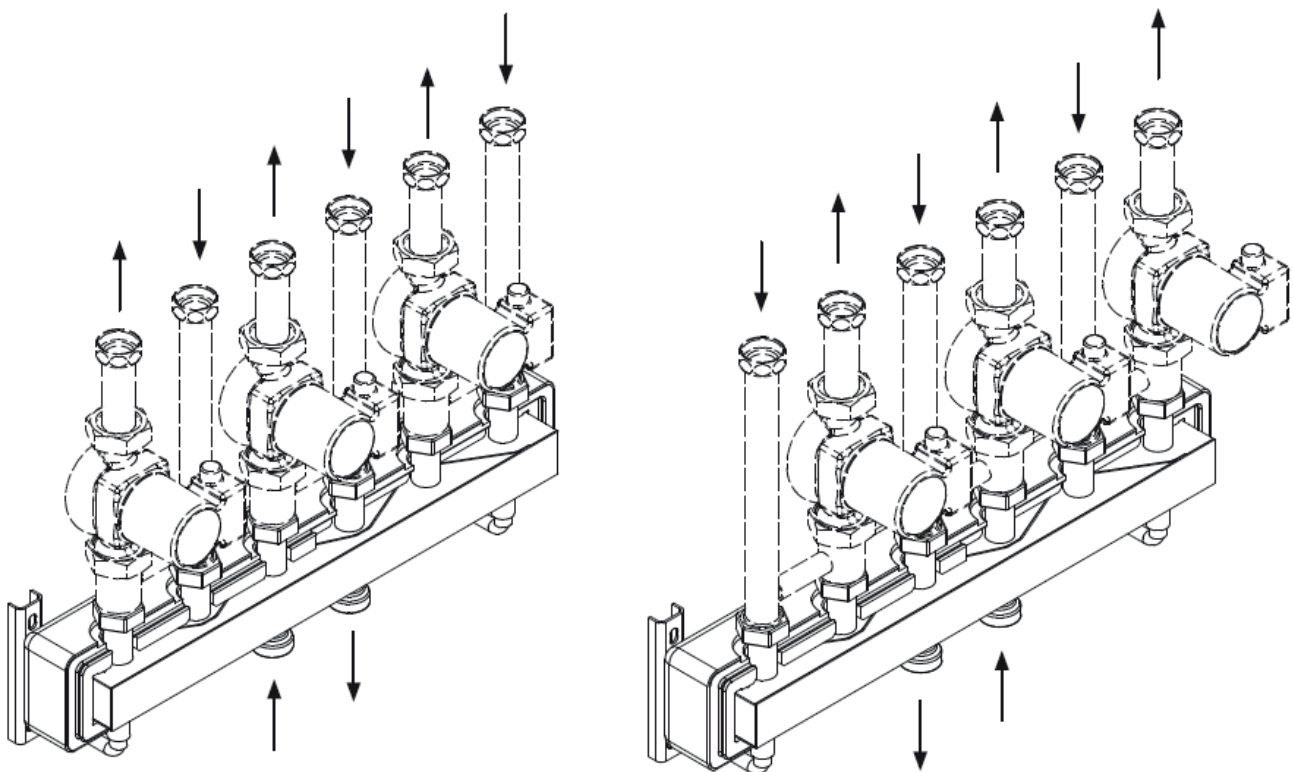
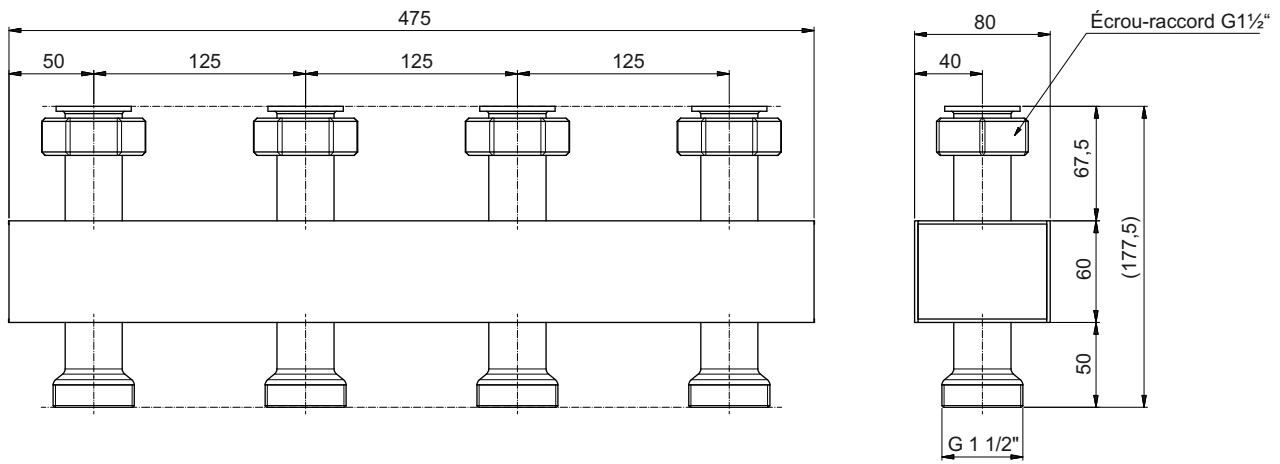

Table des matières

1	Plan coté	FR-2
1.1	Barre de distribution VTB 25-2	FR-2
1.2	Barre de distribution VTB 25-3	FR-3
2	Description du produit et fournitures	FR-4
2.1	Fournitures.....	FR-4
2.2	Caractéristiques techniques	FR-5
2.3	Perte de pression.....	FR-5
3	Représentation de la modification du raccordement	FR-6

1 Plan coté

1.1 Barre de distribution VTB 25-2



Avec isolation

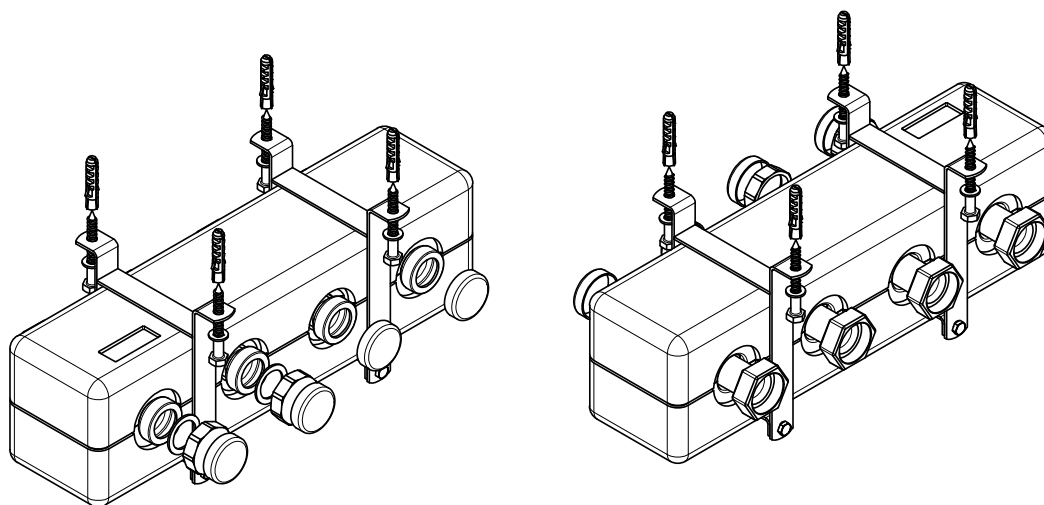
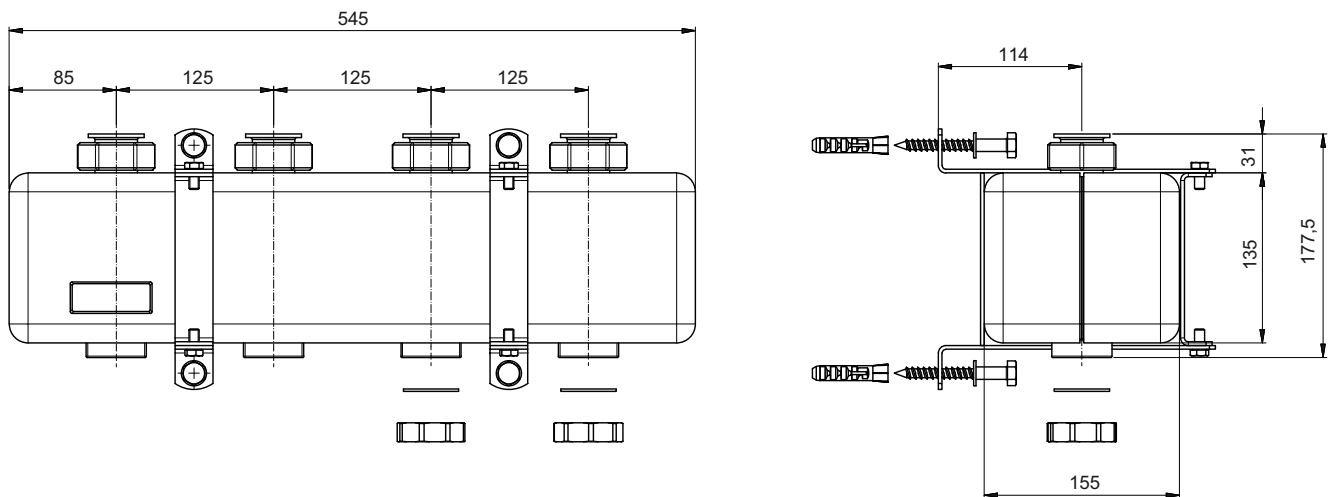

1.2 Barre de distribution VTB 25-3

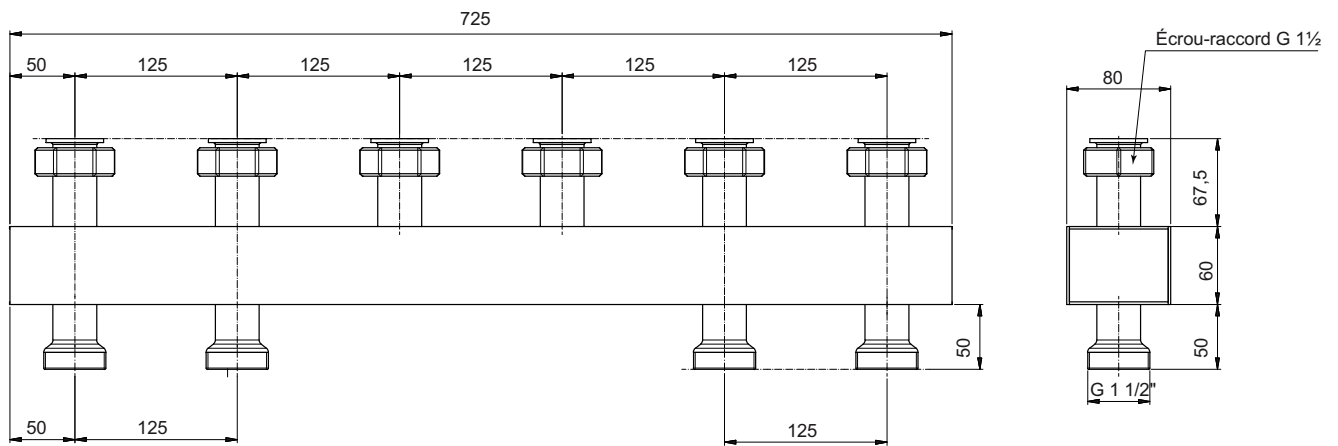

Avec isolation

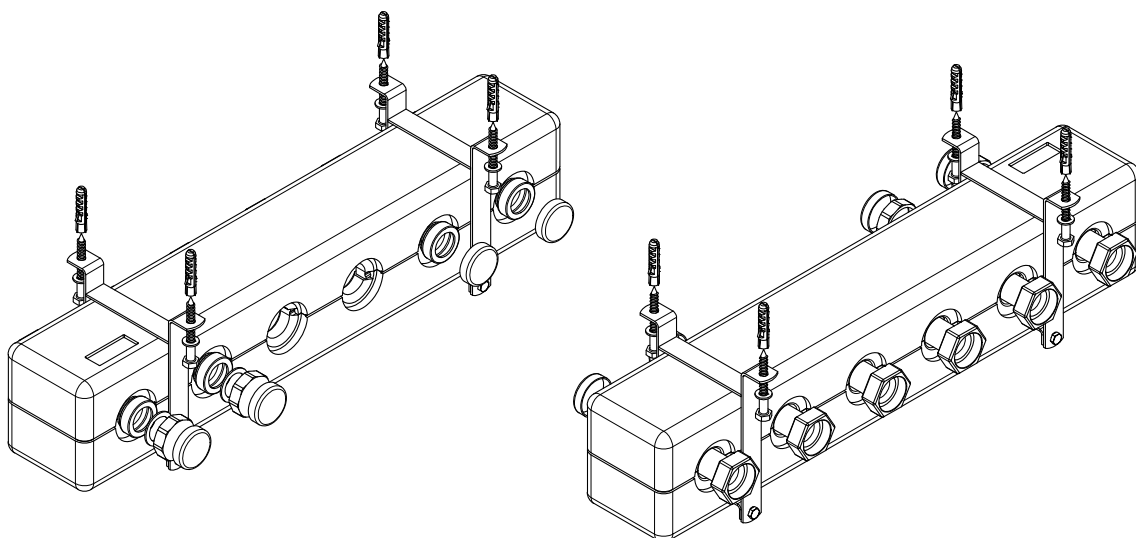
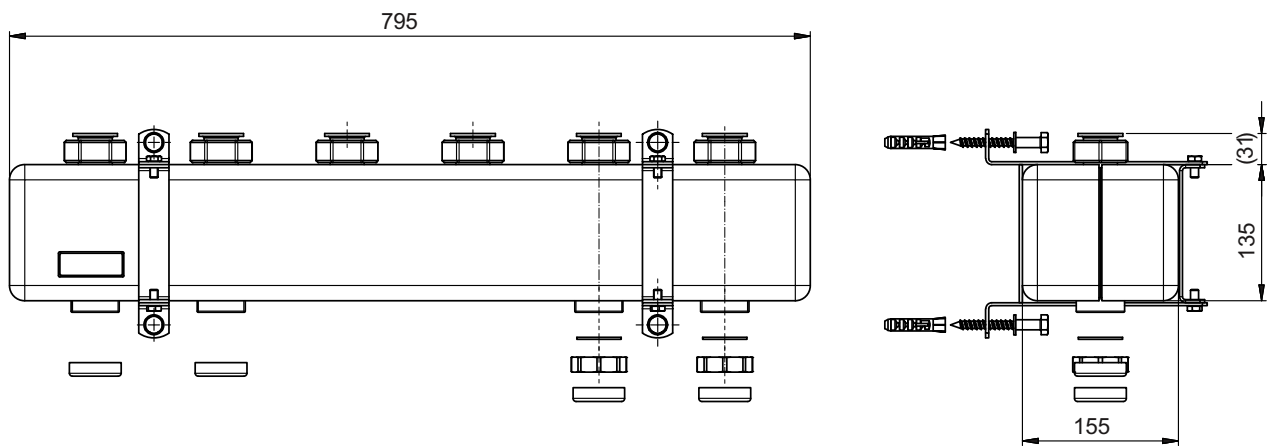

2 Description du produit et fournitures

2.1 Fournitures

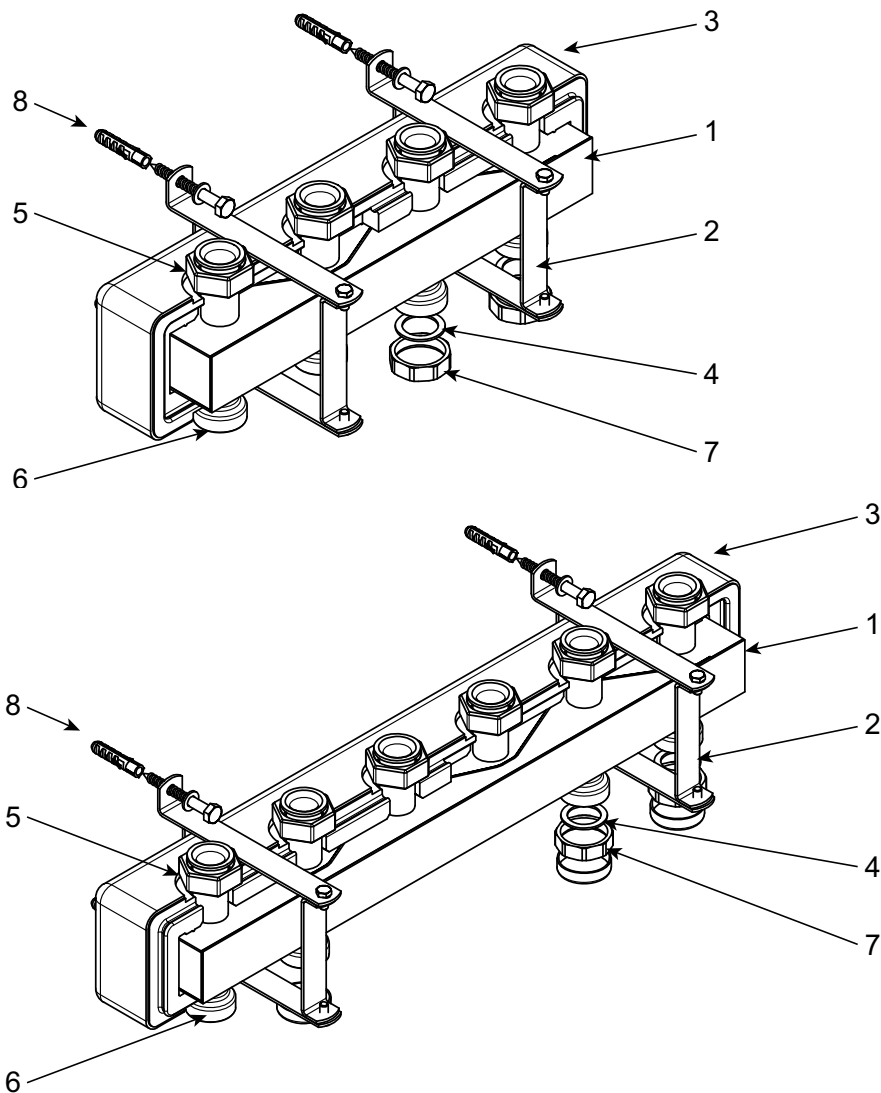

Fonction	Désignation
1	Barre de distribution, écart entre raccords 125 mm
2	Isolation préfabriquée selon RT, mousse EPP 35 mm
3	Console murale
4	Bagues d'étanchéité
5	Écrou-raccord 1 ½" pour raccordement circuit de chauffage
6	Raccord fileté G 1 ½" pour circuit de pompe à chaleur
7	Bouchon 1 ½"
8	Matériel de fixation et de montage

2.2 Caractéristiques techniques

	VTB 25-2	VTB 25-3
Flux volumique max.	3,0 m ³ /h	3,0 m ³ /h
Raccordement circuits de chauffage	Écrou-raccord G 1 ½"	Écrou-raccord G 1 ½"
Raccordement circuit de pompe à chaleur	Filetage extérieur G 1 ½"	Filetage extérieur G 1 ½"
Écart entre raccords	125 mm	125 mm
Pression de fonctionnement max.	4 bar	4 bar
Température de fonctionnement max.	110 °C	110 °C
Volume d'eau du répartiteur	1,9 l	3,0 l

	Nombre de circuits de chauffage	Longueur sans isolation	Longueur avec isolation	Numéro d'article
VTB 25-2	2	475 mm	545 mm	376360
VTB 25-3	3	725 mm	795 mm	376370

2.3 Perte de pression

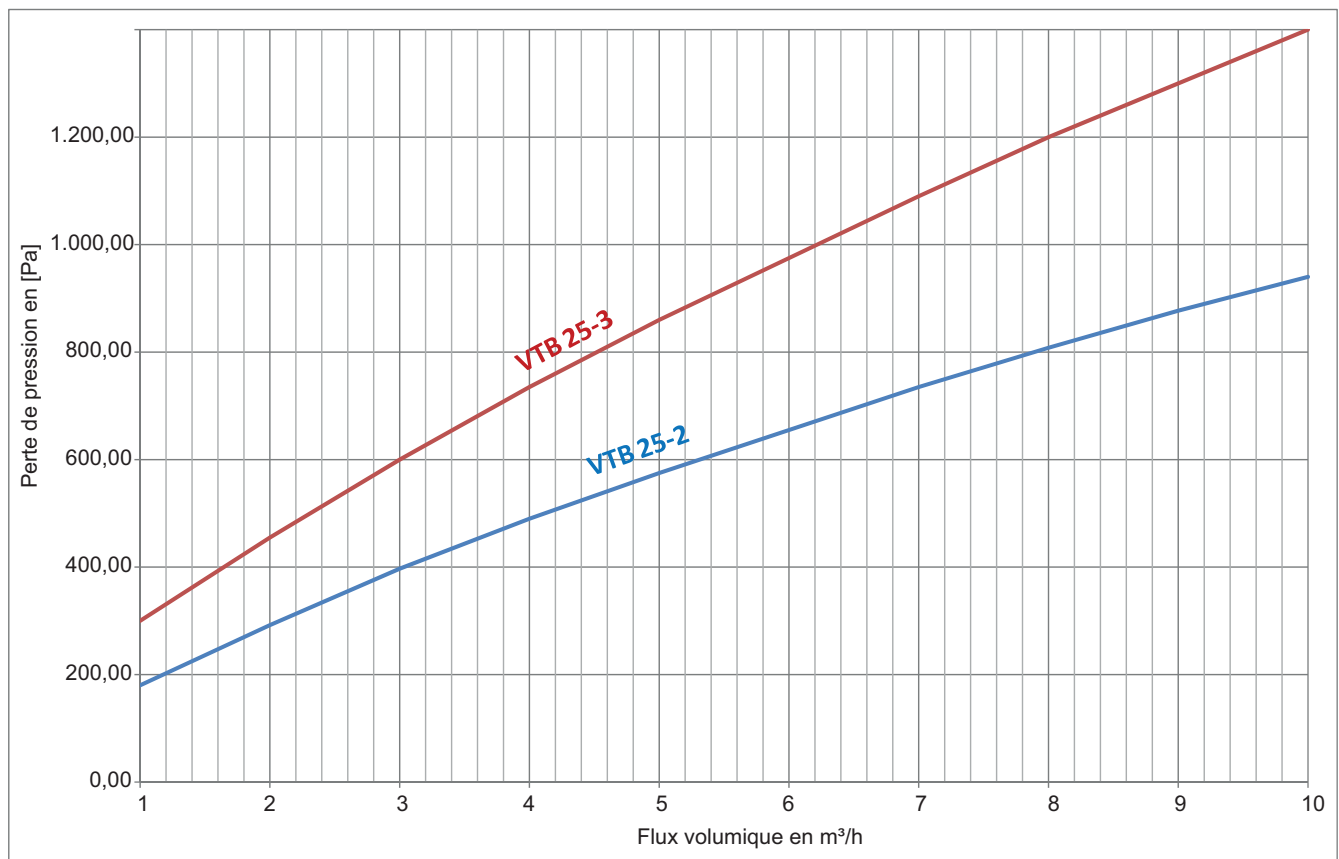

3 Représentation de la modification du raccordement

pour 2 circuits de chauffage

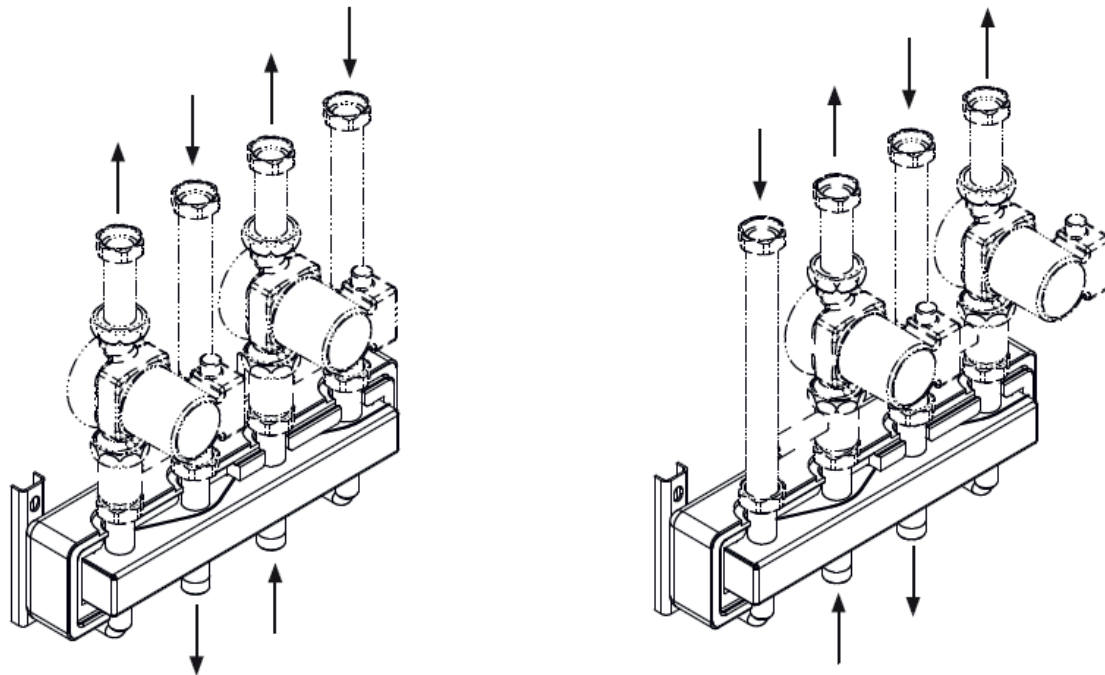

pour 3 circuits de chauffage

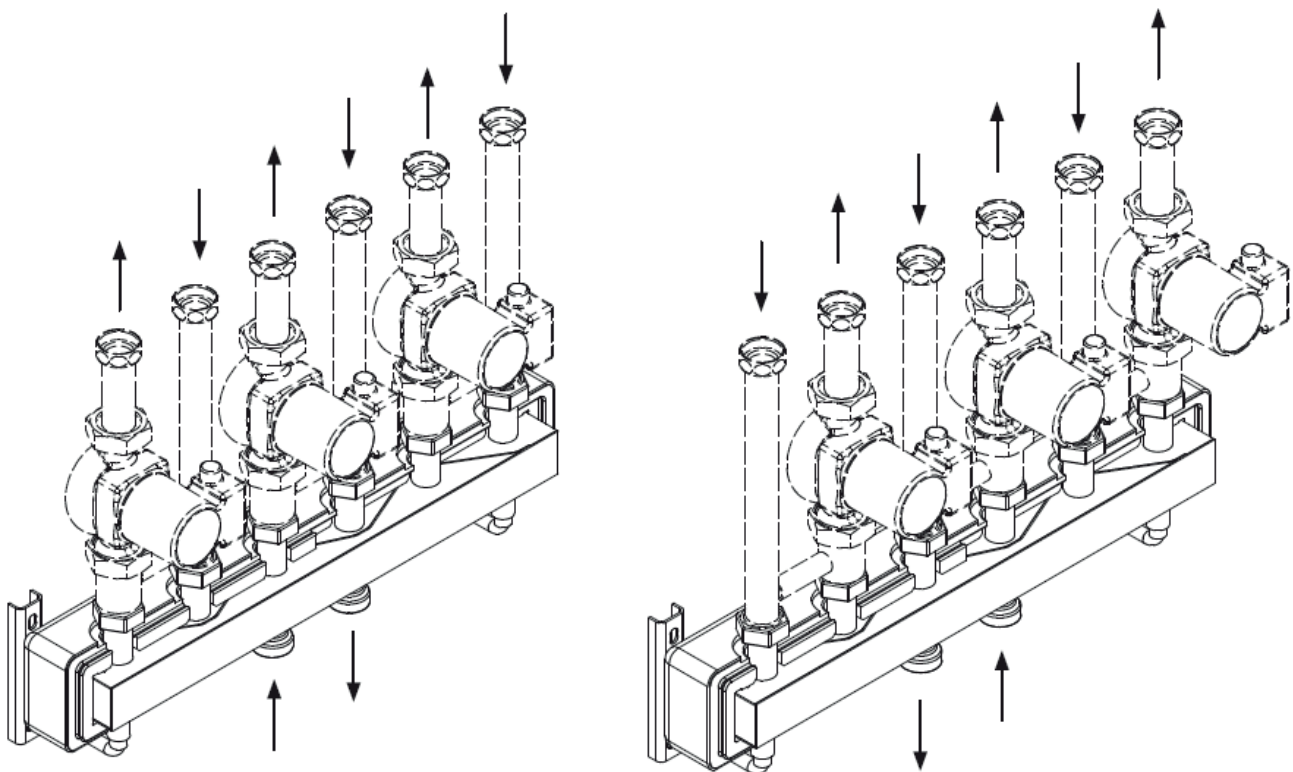

Garantiebedingungen und Kundendienstadresse siehe Montage- und Gebrauchsanweisung Wärmepumpe.

For the terms of the guarantee and after-sales service addresses, please refer to the Installation and Operating Instructions for Heat Pumps.

Pour les conditions de garantie et les adresses SAV, se référer aux instructions de montage et d'utilisation de la pompe à chaleur.

Irrtümer und Änderungen vorbehalten.
Subject to alterations and errors.
Sous réserve d'erreurs et modifications.